

News Release

FOR IMMEDIATE RELEASE

Hitachi Automotive Systems Extends Promotion Partner Agreement for Japanese Super Formula Championship

Tokyo, March 29, 2017 ---Hitachi Automotive Systems, Ltd. today announced that the company will extend its promotion partner agreement with Japan Race Promotion Inc., which will continue to hold the Japanese Super Formula Championship Series in 2017.

Hitachi Automotive Systems has supported the Japanese Super Formula Championship Series, and has been a promotion partner since the 2014 series. As a sponsor, the Hitachi logo has been displayed on all Super Formula cars competing in the seven races held each year.

Every year, drivers with exceptional race standings, both in Japan and abroad, compete in the championship, thrilling spectators with their heated competition. The championship is drawing attention from motor sports fans around the world, with one of last year's competing drivers going on to become an F1 driver. As with last year, champion drivers from GP2, considered the world's second greatest motor sport category, following F1, plan to take part in the 2017 championship, and a new team will also be taking part. This will be a can't-miss season for motor sports fans.

Hitachi Automotive Systems will continue to use its sponsorship of motor sports, including the Japanese Super Formula Championship Series, to further grow the Hitachi brand and contribute to motor sports.



Start of the opening race of the 2016 season (Suzuka Circuit)

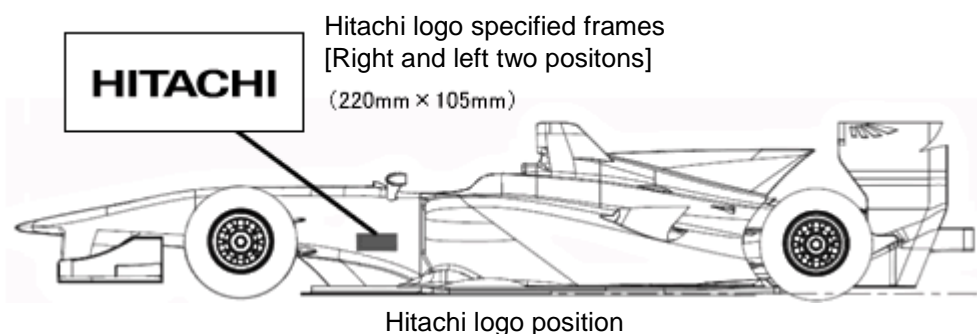

■ Schedule for the 2017 Japanese Super Formula Championship Series

Round	Date	Location	Circuit
1st round	April 22 to 23	Suzuka, Mie Prefecture	Suzuka Circuit
2nd round	May 27 to 28	Mimasaka, Okayama Prefecture	Okayama International Circuit
3rd round	July 8 to 9	Suntou, Shizuoka Prefecture	Fuji International Speedway
4th round	August 19 to 20	Haga, Tochigi Prefecture	Twin Ring Motegi
5th round	September 9 to 10	Hita, Ooita Prefecture	Autopolis
6th round	September 23 to 24	Shibata, Miyagi Prefecture	Sportsland SUGO
7th round	October 21 to 22	Suzuka, Mie Prefecture	Suzuka Circuit

About Hitachi Automotive Systems, Ltd.

Hitachi Automotive Systems, Ltd. is a wholly owned subsidiary of Hitachi, Ltd., headquartered in Tokyo, Japan. The company is engaged in the development, manufacture, sales and services of automotive components, transportation related components, industrial machines and systems, and offers a wide range of automotive systems including engine management systems, electric power train systems, drive control systems and car information systems. For more information, please visit the company's website at <http://www.hitachi-automotive.co.jp/en/>.

###